

Electronic Ballast with Wide Dimming Range: Matlab-Simulink Implementation of a Double Exponential Fluorescent-Lamp Model

Marina Perdigão¹ and E. S. Saraiva²

¹ Departamento de Engenharia Electrotécnica
Instituto Superior de Engenharia de Coimbra
Rua Pedro Nunes 3030-199 Coimbra, Portugal
e-mail: perdigao@mail.isec.pt

² Departamento de Engenharia Electrotécnica e de Computadores
Faculdade de Ciências e Tecnologia da Universidade Coimbra
Polo II, P-3030-290, Coimbra, Portugal,
e-mail: esaraiva@deec.uc.pt

Abstract: In this paper, a systematic approach is developed to derive lamp parameters from experimental data, in order to produce a dynamic fluorescent lamp model using Matlab/Simulink. It can be concluded from experimental and simulation results that the proposed model is adequate to simulate the behaviour of the lamp.

Key Words: fluorescent-lamp model, simulation, curve fitting, electronic ballast, dimming, Matlab/Simulink.

1. Introduction

High-frequency operation of fluorescent lamps is a technique with increasing use, with the objective of upgrading the quality of fluorescent lighting systems. It is well known that fluorescent lamps operating at high frequencies present a higher luminous efficacy. Since fluorescent lamps present a negative resistance characteristic, a current controlling ballast is necessary, in order to limit the discharge current. Computational fluorescent-lamp models, which accurately simulate the real behaviour of fluorescent lamps, became extremely necessary. These high-frequency fluorescent-lamp models are used for optimization studies on conception of electronic ballasts. Existing literature refers to several fluorescent-lamp models, [1], [2], [3], [4], [5].

Traditionally, these models are implemented in circuit-simulation programs, such as SPICE-based programs. In this paper it is proposed a monotonic double exponential model for the resistance of the fluorescent lamp. The chosen environment was Matlab/Simulink, which allows more complicated and intensive mathematical calculations, providing a full new horizon in terms of simulating this type of fluorescent lighting systems.

The simulation of a fluorescent lighting system which includes an electronic ballast with wide dimming range is the focus of this paper. Electronic ballasts with dimming are increasingly used. This dimming capability may be achieved by several techniques. One of the most common

is based on the control of the inverter frequency that feeds the series-resonant parallel load which includes the fluorescent lamp. This is the method adopted in this paper. It is also presented how the implementation of the fluorescent-lamp model is done, and compares simulation results with the ones experimentally obtained, in order to validate this Matlab-Simulink implementation of the model.

2. Dynamic Fluorescent-Lamp Model

A. Model Theory

The model that was chosen for implementation consists in a simple equation capable of describing the electrical characteristics of the lamp at high frequency. The fluorescent-lamp model presented is based on equation (1) which represents a curve fitting to the experimental data of equivalent resistance versus average power, using only monotonically decreasing functions based on exponentials. The Levenberg-Mardquard algorithm was chosen for this curve-fitting.

$$R_{\text{lamp}} = \mathbf{a}e^{-\mathbf{b}P_{\text{lamp}}} + \mathbf{c}e^{-\mathbf{d}P_{\text{lamp}}} \quad (1)$$

Considering the future implementation of the model in Matlab/Simulink, a simple adaptation can be made if, instead of considering the lamp resistance, we consider the lamp conductance. So, for dynamic studies lamp voltage and lamp current can be related as follows:

$$i_{\text{lamp}}(t) = \mathbf{G}_{\text{lamp}}(t) \times v_{\text{lamp}}(t) \quad (2)$$

B. Lamp Model Parameters Estimation

The measured data of a F36W/54 General Electric fluorescent lamp are presented in Table 1. These data were obtained with an electronic ballast with dimming: Quicktronic Delux HF 2x36/230-240 DIM. This ballast

Table 1 V-I characteristics of a F36W/54 General Electric fluorescent lamp for different dimming levels

Power level	V _{RMS} [V]	I _{RMS} [A]	P _{AVG} [W]	R _{lamp-VI} [Ω]	R _{lamp-PI} [Ω]	$\frac{\Delta R_{lamp}}{R_{lamp}}$ %	Frequency [KHz]
maximum ↓ ↓ ↓ ↓ ↓ ↓ ↓ ↓ minimum	99.5393	0.2888	28.2260	344.61	338.3	1.848	51.653
	103.1804	0.2576	26.0112	400.49	391.88	2.173	57.339
	104.6403	0.2321	23.8078	450.84	441.93	1.996	61.125
	110.9816	0.1974	21.4655	562.32	551.08	2.019	68.871
	113.2090	0.1821	20.1859	621.71	608.79	2.099	72.046
	114.1565	0.1690	18.8594	675.51	660.38	2.265	75.586
	120.2613	0.1424	16.7430	844.35	825.32	2.279	80.775
	126.6726	0.1134	14.0515	1117.2	1093	2.189	85.470
	143.8952	0.0417	5.8999	3447.4	3386.4	1.785	90.909

has a two terminal control input that allows the setting of the dimming level using a 1-10 V positive control voltage source. The instantaneous lamp current was obtained using an AC/DC current probe Tektronix A6302 and a current amplifier Tektronix AM503. The instantaneous lamp voltage was obtained using a differential voltage probe Tektronix P5200 in the 1/500 scale. A Tektronix 2014 oscilloscope was used to visualize the waveforms and to do the data acquisition. The rms and average values presented in Table 1 were calculated offline with a Matlab program because of the limitations of the algorithm used by the oscilloscope.

In Table 1 two columns for the equivalent resistance of the lamp are presented. One, named $R_{lamp-VI}$, is based on the division of the rms values of lamp voltage and lamp current. The other, named $R_{lamp-PI}$, is based on the division of the average lamp power by the square of rms lamp current. These resistance values are not identical because the waveforms of lamp voltage and lamp current are not exactly sinusoidal and identical. The maximum and minimum relative differences are found to be 2.279% and 1.785% using equation (3).

$$\frac{\Delta R_{lamp}}{R_{lamp}} = \frac{2(R_{lamp-VI} - R_{lamp-PI})}{R_{lamp-VI} + R_{lamp-PI}} \quad (3)$$

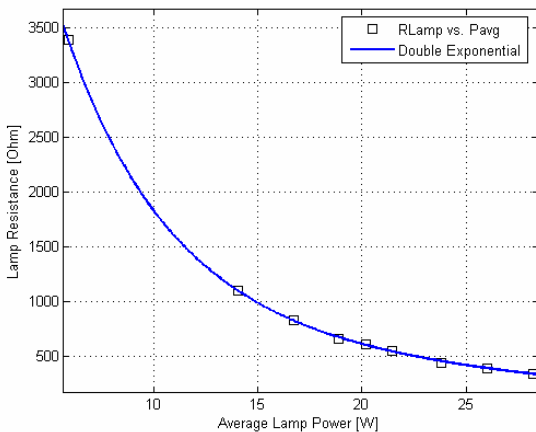

Fig. 1 Curve fitting to the R-P characteristics of a F36W/54 General Electric fluorescent lamp

Fig. 1 presents the curve fitting for the $R_{lamp-PI}$ vs the average lamp power, P_{AVG} . This model implies a monotonically decreasing lamp equivalent resistance with a maximum value at zero power level. The result of curve fitting is:

$$R_{lamp} = 8147e^{-0.2113P_{lamp}} + 1433e^{-0.05353P_{lamp}} \quad (4)$$

3. Electronic Ballast and equivalent circuit, design procedure

The basic configuration of the half-bridge series-resonant parallel loaded system is shown in Fig. 2.

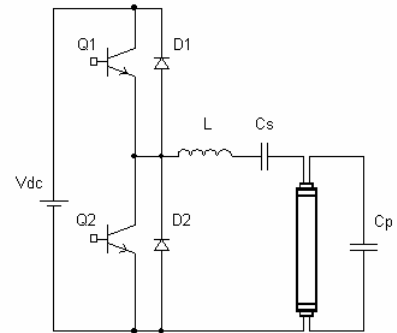

Fig.2 Circuit topology of the half-bridge series-resonant parallel-loaded inverter

Supposing V_{dc} constant, if the quality factor of the load is sufficiently high, the current through the resonant circuit is sinusoidal and the currents through the switches are half-wave sinusoids. The voltages across the switches are square waves [6]. If the fluorescent lamp is off, it behaves as an open circuit, presenting almost infinite impedance. If the fluorescent lamp is on, its impedance presents finite values. Fig. 3 represents the equivalent simplified circuit of the series resonant parallel-loaded ballast for the lamp off state. This resonant circuit is a third-order low-pass filter that delivers power to the load mainly by the fundamental frequency. $V_{s,1}$ represents the rms value of the fundamental component.

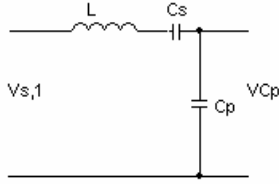

Fig.3 Equivalent simplified circuit of the series resonant parallel-loaded ballast

As can be seen from Fig. 4, which shows the experimental measure of the inverter output voltage of the Quicktronic Delux HF 2x36/230-240 DIM ballast, the inverter voltage is essentially square-wave with a dc component. This confirms the theoretical assumption made earlier. However, if another time scale is used, 5ms/div, as shown in Fig. 5 for the maximum power level the DC voltage has a non negligible alternate component.

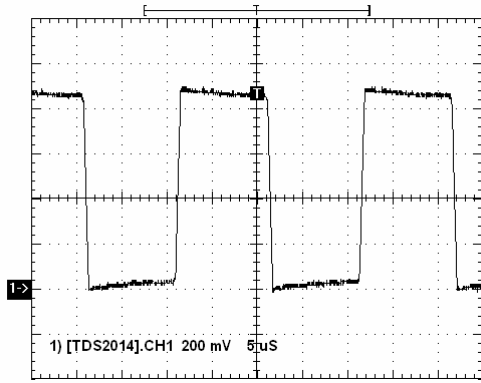

Fig. 4 Experimental results: Inverter output voltage for maximum power level; voltage 100 V/div, time base 5μs/div

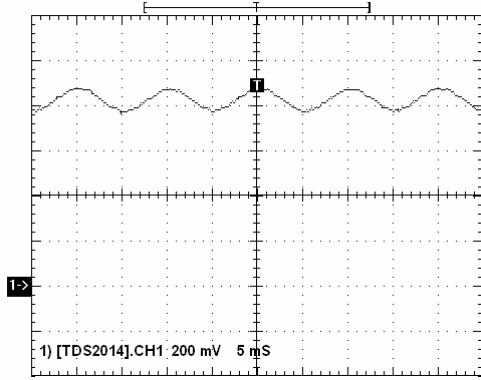

Fig. 5 Experimental results: DC busbar voltage for maximum power level; voltage 100 V/div, time base 5ms/div

Considering the simplified circuit of Fig. 3 we can establish the following relations:

$$\frac{V_{Cp}}{V_{s,1}} = \frac{1}{j\omega L + \frac{1}{j\omega C_s} + \frac{1}{j\omega C_p}} \times \frac{1}{j\omega C_p} \quad (5)$$

So:

$$\frac{V_{s,1}}{V_{Cp}} = \left| 1 + \frac{C_p}{C_s} - \omega^2 LC_p \right| \quad (6)$$

Since the resonant inverter is operated above resonance,

$1 + \frac{C_p}{C_s} < \omega^2 LC_p$, which means that:

$$LC_p = \frac{1 + \frac{C_p}{C_s} + \frac{V_{s,1}}{V_{Cp}}}{\omega^2} = \frac{1 + A + \frac{V_{s,1}}{V_{Cp}}}{\omega^2} \quad (7)$$

According to [7], a value for $A = \frac{C_p}{C_s}$ between 0.1-0.25 would normally be adequate for most ballast applications.

A small Matlab program was developed to establish the approximate values for the electronic ballast parameters. Using equation (7), the parameters C_p and C_s were determined by setting different values for L and for A , considering a switching frequency of 90.909 kHz, which corresponds to the minimum power level. In equation (7)

$V_{s,1} = \frac{4V_{dc}}{2\pi \times \sqrt{2}} = \frac{800}{\pi \times \sqrt{2}} \text{ V}$ and $V_{Cp} = 143.8952 \text{ V}$. A small corrective factor is applied to V_{Cp} because the

lamp does not really present infinite impedance when at minimum power level. Since the schematic of the electronic ballast used in the laboratory was not known, an iterative method was used. Fig. 6 represents the equivalent simplified circuit of the series resonant parallel-loaded ballast for the minimum power level. Instead of considering the lamp resistance as infinite or almost infinite, we consider its experimental value. In Fig. 6 R_f' represents the resistance of the filaments in the lamp.

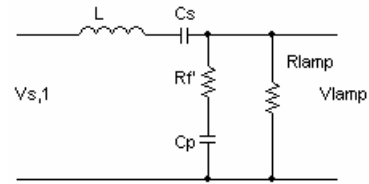

Fig. 6 Equivalent simplified circuit of the series resonant parallel-loaded ballast for the minimum power level

From Fig. 6, the lamp voltage can be expressed as:

$$\frac{V_{lamp}}{V_{s,1}} = \frac{Z_p}{Z_p + Z_s} \times Z_p \quad (8)$$

where Z_p represents the impedance of the parallel branches and Z_s the impedance of the series branch:

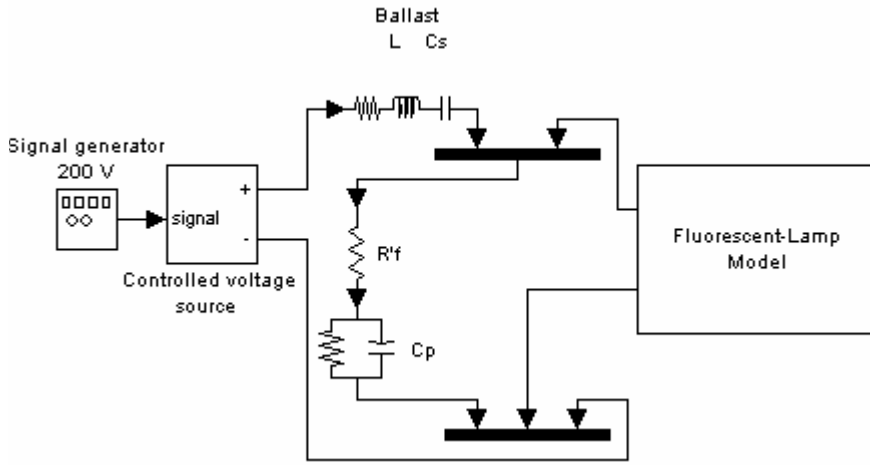

Table 2 Simulink model parameters

Double Exponential Model
$a = 8147; b = -0.2113;$
$c = 1433; d = -0.05353$
Time constant $\tau = 3 \times 10^{-4}$
$R'_f = 2 \times 9.6 \Omega$
Electronic ballast
$V_{s,1} = \frac{800}{\pi \times \sqrt{2}} \text{ V}$
$L = 2.2358 \times 10^{-3} \text{ H}$
$A = 0.1307$
$C_p = 3.1639 \times 10^{-9}$
$C_s = 2.4207 \times 10^{-8}$

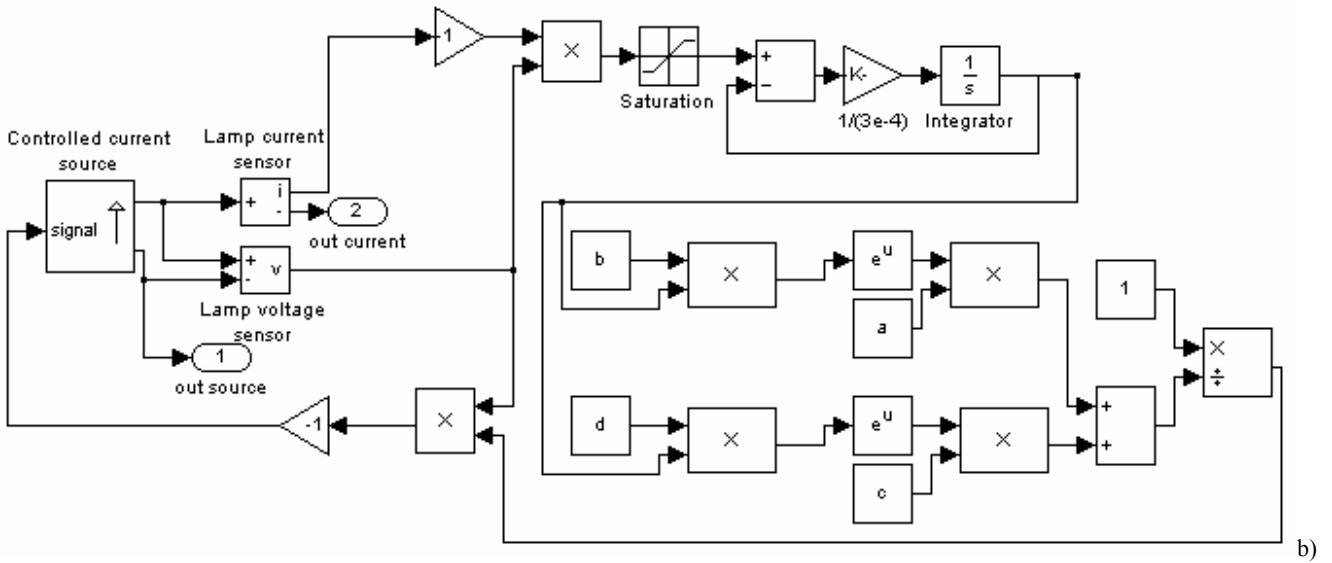

Fig. 9: a) Schematic of the electronic ballast; b) Schematic of the double exponential fluorescent-lamp model.

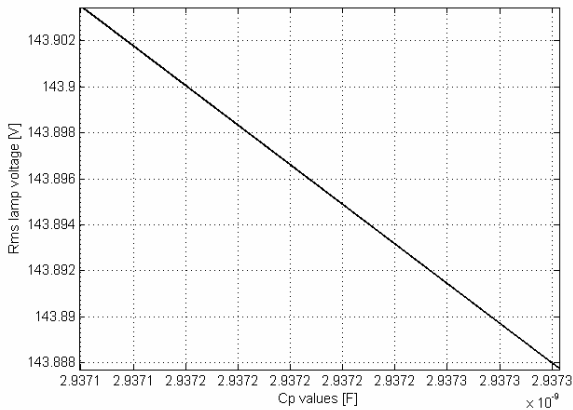

Fig. 7 Evolution of the rms lamp voltage as a function of C_p for the minimum dimming level

$$Z_p = \frac{1}{Y_p} = \frac{1}{\frac{1}{R_{lamp}} + \frac{1}{R'_f + \frac{1}{j\omega C_p}}} \quad (9)$$

$$Z_s = j\omega L + \frac{1}{j\omega C_s} \quad (10)$$

Another Matlab program was developed in order to implement equation (8). Introducing of the following values: $\omega = 2\pi \times 90909$, $A = 0.1307$, $L = 0.0024$, $V_{s,1} = \frac{800}{\pi \times \sqrt{2}}$ and considering that $C_s = \frac{C_p}{A}$, the plot represented in Fig. 7, which shows the lamp voltage module as a function of C_p was obtained.

The analysis of Fig. 7 leads to the conclusion that an accurate value for C_p is approximately, 2.9372×10^{-9}

F, so $C_s = \frac{C_p}{A} = \frac{2.9372 \times 10^{-9}}{0.1307} = 2.2473 \times 10^{-8}$ F. These

new values lead to a new analytical solution but maintaining the initial guesses for L and A. The difference between the experimental results and analytical values of the lamp voltage and lamp current were analysed and other guesses for L and A were chosen. The process was repeated until sufficient accuracy was obtained. The final results are shown in Table 2 and Fig.8.

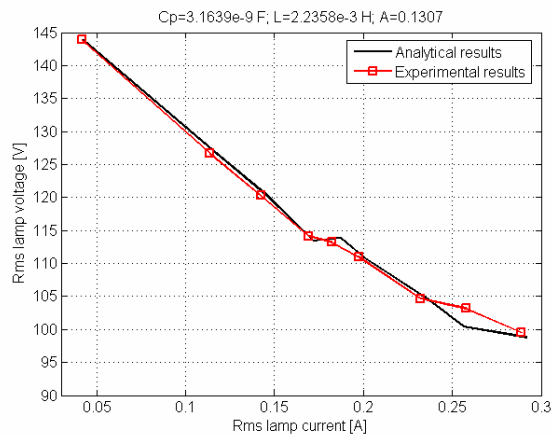

Fig. 8 Experimental and analytical results of the rms lamp voltage vs rms lamp current for the best curve fitting of the electronic ballast parameters

4. Matlab/Simulink Implementation of the Fluorescent-Lamp Model

A. Model Description

The main objective is to try to simulate the behaviour of a fluorescent lighting system with wide dimming range similar to the one obtained in the laboratory. Fig. 8 shows the schematic of the electronic ballast that was implemented. Fig. 9a) shows the schematic of the electronic ballast that was implemented. The electronic ballast parameters and the fluorescent-lamp model parameters are shown in Table 2. The double exponential fluorescent-lamp model was implemented in Matlab/Simulink as shown in Fig. 9b). Lamp current and lamp voltage are sensed and multiplied. The resulting instantaneous power is then filtered in order to estimate the low-pass filtered lamp power. The time constant of the filter is related to the ionization constant of the arc discharge. Subsequently, equation (1) is implemented. Lamp current is generated by a controlled current source, controlled by the results of equation (2), and obtained using Simulink blocks.

B. Simulation Results

Fig. 10, Fig. 12 and Fig.14 show lamp current and lamp voltage waveforms obtained with laboratory experiments at different dimming levels. Fig. 11, Fig. 13 and Fig.15 show the simulation results for lamp current and lamp voltage waveforms, considering the double exponential model, for the same dimming levels.

From Fig. 10, at a lower frequency, we can observe that the lamp voltage is slightly different from a sine wave, showing a tendency to a triangular-like form. At high power levels, since the DC voltage has a non negligible alternate component at 100 Hz, the experimental results depend on the instant of sampling. So it is natural to observe some discrepancies between simulation and experimental results, particularly on the rms values of lamp voltage and lamp current. Nevertheless the simulation and experimental results are similar.

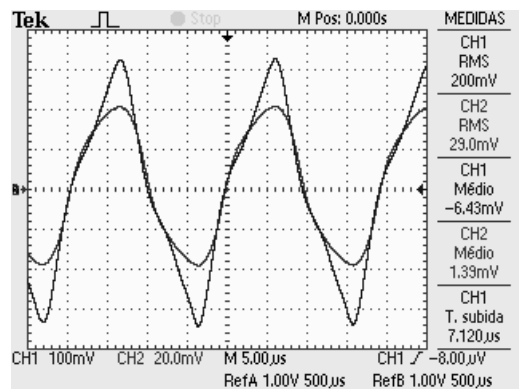

Fig. 10 Experimental results: lamp voltage and lamp current waveforms at 51.653 kHz; voltage 50 V/div, current 0.2 A/div.

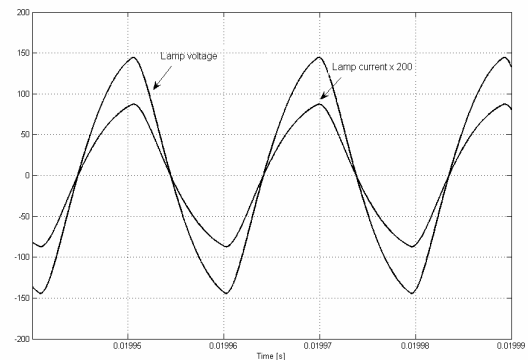

Fig. 11 Simulation results: lamp voltage and lamp current waveforms at 51.653 kHz

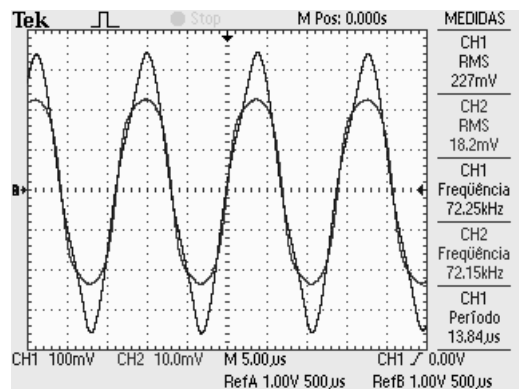

Fig. 12 Experimental results: lamp voltage and lamp current waveforms at 72.046 kHz; voltage 50 V/div, current 0.1 A/div.

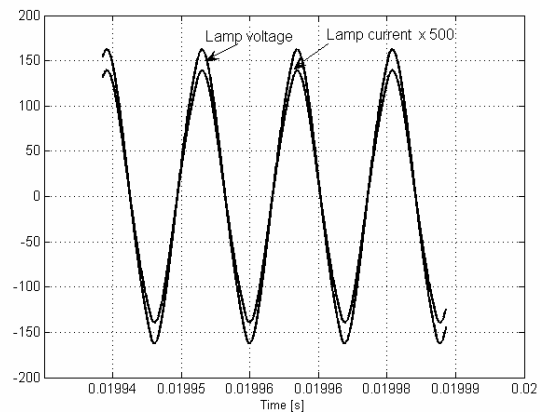

Fig. 13 Simulation results: lamp voltage and lamp current waveforms at 72.046 kHz

As the lamp power level decreases, the lamp voltage waveform becomes increasingly sinusoidal, which is observed from both experimental and simulation results. The lamp current waveform shows a different behaviour, with a tendency to flatten the peaks as the lamp power level decreases. As can be seen from Fig. 14, at very low power levels, only the lamp voltage waveform can be considered as a sine wave. The lamp current waveform also shows asymmetric behaviour during the switching period, which in turn reflects the different aging effect of the electrodes. This effect was not accounted for in the simulation program. However, from the rms point view the obtained simulation results are similar to the experimental ones.

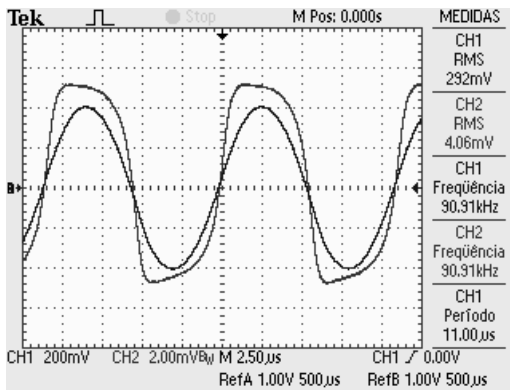

Fig. 14 Experimental results: lamp voltage and lamp current waveforms at 90.909 kHz; voltage 100 V/div, current 0.02 A/div.

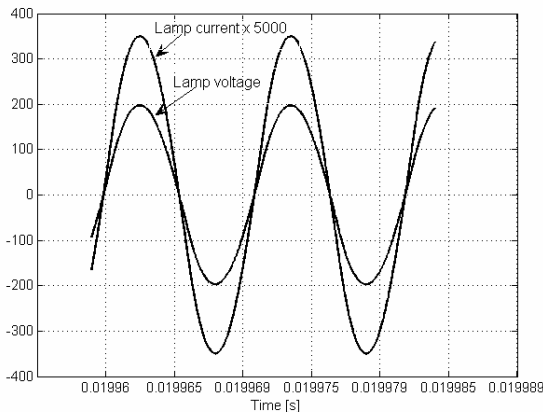

Fig. 15 Simulation results: lamp voltage and lamp current waveforms at 90.909 kHz

5. Conclusion

In this paper it is proposed a new fluorescent-lamp model based on the value of the equivalent resistance of the lamp expressed as a decreasing monotonic double exponential function of average lamp power. The resulting curve fitting represents a good approximation to the experimental results. Two methods were tested to calculate the equivalent lamp resistance, the first one based on the division of the rms values of lamp voltage

and lamp current, the second based on the division of the average lamp power by the square of rms lamp current. The second method was preferred because it really represents the lamp resistance versus average lamp power. The first method would give us the lamp resistance versus apparent lamp power, since lamp voltage and lamp current waveforms are not exactly sinusoidal and identical.

Using an iterative method, the electronic ballast parameters were obtained, supposing that the dc busbar voltage is constant. Nevertheless this is not valid for higher power levels, as it was observed experimentally. In fact, it is absolutely necessary that the DC capacitor should be able to filter the DC voltage at a reasonable level in order to get a very low ripple and consequently a stable light output.

Since at higher power levels lamp voltage and lamp current are not sine waves, the theoretical approach considering only the fundamental component of the inverter voltage may not be accurate. In fact when a dynamic simulation is made, the lamp voltage and lamp current waveforms are not sinusoidal and are similar to the experimental results.

The proposed model can be used for simulation purposes, if second-order effects are ignored.

6. References

- [1] Mader, U., and Horn, P., "A Dynamic Model for the Electrical Characteristics of Fluorescent Lamps", IEEE Industry Applications Society Meeting, Conf. Records 1992, pp 1928-1934.
- [2] Wu, T. F., Hung, J. C., and Yu, T. H., "A Pspice Model for Fluorescent Lamps Operated at High Frequencies", Proceedings of IECON'95, 1995, pp 359-364.
- [3] Chin S. Moo, Ying C. Chuang, Yung H. Huang, Horn N. Chen, "Modeling of Fluorescent Lamps for Dimmable Electronic Ballasts", IAS'96, Industry Applications Conference, Conference Record, 1996, vol. 4, pp 2231-2236.
- [4] C. A. Cheng, T. J. Liang, C. M. Chuang and J. F. Chen, "A Novel Method of Using Second-Order Lamp Model to Design Dimmable Fluorescent Lamps Electronic Ballast", IECON'01, The 27th Annual Conference of the IEEE Industrial Electronics Society, Proceedings of IECON'01, 2001, pp 1033-1037.
- [5] Naoki Onishi, Tsutomu Shiomi, Akio Okude and Tokushi Yamauchi, "A Fluorescent Lamp Model for High Frequency Wide Range Dimming Electronic Ballast Simulation", Proceedings of APEC'99, vol. 2, pp 1001-1005
- [6] Kazimierczuk, Marian K., Czarkowski, Dariusz, *Resonant Power Converters*, John Wiley & Sons, Inc., 1995.
- [7] Alonso, J. Marcos, *Electronic Ballasts*, *Power Electronics Handbook*, Muhammad Rashid, Editor-in-Chief, Academic Press, 2001, pp 507-532.