

Low-cost Advanced Metering Infrastructure for Residential Applications

Mañana M¹, Ortiz A¹, Renedo C.J¹, Pérez S¹, Delgado F¹, Cavia M.A¹, Ruiz J²

¹ Department of Electrical and Energy Engineering
University of Cantabria
Santander, Spain
email: mananam@unican.es

² Energy Watch Consulting
Torrelavega, Spain
email: jrconde@eweglobal.org

Abstract. This research work introduces the architecture of a low-cost advanced metering infrastructure (AMI) named DANCA with the ability to record up to six different current channels with the same voltage. This watt-hour meter can send the recorded power and energy data in real-time to a web server using both an ethernet wired and an IEEE 802.11b Wi-Fi wireless connection. The server stores the data measured by the meters and can elaborate reports with useful data for the users. The clients can access the data in real-time using a web browser.

From an instrumentation point of view the developed system can measure the power and energy consumption of clusters of loads in residential and small industrial applications. From the point of view of the connectivity the system can communicate with the server using the domestic internet access point. The amount of data to be transmitted is very low so the impact of the system in the network bandwidth can be considered negligible.

Keywords: smart metering, smart grids, instrumentation.

I. INTRODUCTION

The development of SmartGrids in Europe has been defined, from a political point of view, by Directive 2006/32/EC of the European Parliament and of the Council of 5 April 2006 on energy end-use efficiency and energy services and repealing Council Directive 93/76/EEC [1]. This document introduces the necessity of using parameters to evaluate the efficiency on the use of the electrical energy. In addition, these parameters should be implemented in new smart meters. Most of the European countries have developed local policies that implement the Directive 2006/32/EC from different points of view. The Spanish Government developed the Ministerial Order ITC/3860/2007 [2] in 2007. This document establishes compulsory requirements for energy meter devices. For instance, the Ministerial Order says that all watt-hour meters

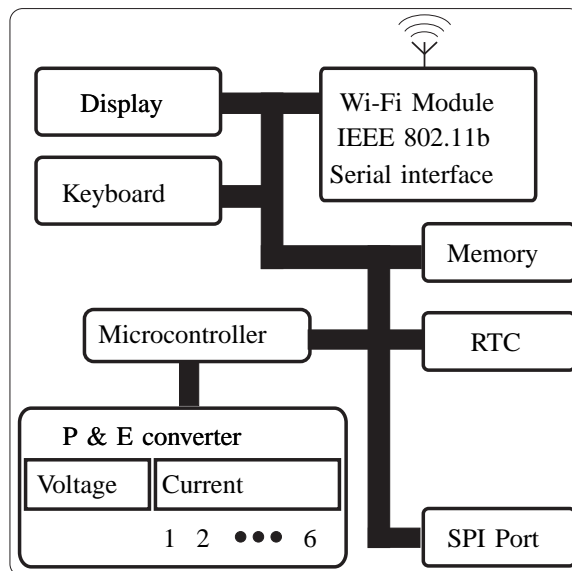

Fig. 1: Block diagram of the proposed meter.

connected in installations with a nominal power up to 15 kW have to be upgraded to new electronic devices with storage capacity and remote control and monitoring before the 31th of december of 2018. In addition to the legal requirements the utilities are defining their own strategies in order to improve the monitoring process. It is important to understand that the introduction of smart grids will increase the complexity of the metering process [3], [4], [5].

In the near future the metering paradigm will change from a model where energy consumption is provided to the user in a per-month interval to a model that gives to the user the energy consumption in real-time, not only for information purposes but also for controlling the connection of loads that can be modulated in time.

II. HARDWARE ARCHITECTURE

From a general point of view, new watt-hour meters are designing according two different technologies:

1. Watt-hour meters designed from the perspective of the utilities.
2. Watt-hour meters designed considering the requirements of final users.

II-A. Power and Energy Measurement

The measurement of power and energy can be implemented using different technologies:

- Digital software.
- Digital hardware.
- Analog hardware.

The developed meter computes power and energy using a digital hardware implementation. The controller can be used to another tasks like data management, communications and user interface. The power and energy conversion is implemented using a CS5464 integrated circuit (IC) manufactured by Cirrus Logic [6]. The CS5464 can be considered as a watt-hour meter on a chip with an energy linearity is $\pm 0.1\%$ of reading over a dynamic range of 1000:1.

Using three CS5464 it is possible to measure power and energy in two different loads of a three-phase system or six loads in a single-phase installation. This approach is the most important contribution of this work because the meter is able to monitor power and energy in a disaggregated way.

II-B. Control unit

The control unit is based on a microcontroller Microchip PIC18F97J60 [7]. This device can be considered a 8-bits, high-Performance, 1-Mbit flash Microcontroller with ethernet. The control unit also includes external flash memory, real time clock, LCD, keyboard and an IEEE 802.11b Wi-Fi module.

II-C. Wireless communication

The wireless communication has been implemented using a module that fulfill the standard IEEE 802.11b and also includes a web server. The device is based on the Digi Connect architecture for embedded products that enable controllers to implement Wi-Fi or wired features using a serial interface. The module is based on a NetSilicon 32-bit NET+ARM technology that can be used as the control core or only as a communication module.

A GUI based on a web browser has some advantages:

- It is platform independent so it does not matter if the user has windows, mac or linux operating system.
- It can be found open source and GNU web browsers so the user does not have to pay additional software cost.
- The user does not need a powerful hardware platform because all the computations are performed at the server.
- The user can access to the data in any place with an internet connection.

III. SOFTWARE ARCHITECTURE

The software architecture has two different components. The first one is the firmware that controls the meter and the second one is the software that runs in the web server. Other important element is the web browser. This last component is transparent to the user.

IV. SMART METER SECURITY

In the near future, it is possible that software and hardware will be developed by different vendors, with devices and software applications that are being developed in parallel by metering manufactures, communication providers and back-office Meter Data Management IT vendors. In this scenario it is necessary to improve the security of the overall system. The cyber security of the AMI system is not only concerned with data integrity but also with remote commands like connect or disconnect the power supply. In [8] the problems related with AMI systems are underlined. The basic idea is to introduce security issues from the beginning in order to be truly effective.

V. CONCLUSIONS

The proposed AMI system has an architecture that match the legal requirements established by both the European Union and the Spanish regulations regarding watt-hour meters. The system has been designed considering the necessities that will be introduced by smart-grids. One contribution of this system is the ability to use the domestic Wi-Fi network as a way to send the recorded data to the server. Another contribution is the capacity to measure up to six different loads sharing the same voltage.

ACKNOWLEDGMENT

The authors are grateful for the support from the Spanish Government under the project ENE2007-68032-C04-04 and the Cantabria Government under the INVESNOVA initiative.

REFERENCIAS

- [1] "Directive 2006/32/ec of the european parliament and of the council of 5 april 2006 on energy end-use efficiency and energy services and repealing council directive 93/76/eec." *Official Journal of the European Union*, 27th april. 2006.
- [2] "Orden itc/3860/2007, de 28 de diciembre, por la que se revisan las tarifas eléctricas a partir del 1 de enero de 2008." *BOE núm. 312*, Sábado 29 diciembre 2007.
- [3] A. De Almeida and E. Vine, "Advanced monitoring technologies for the evaluation of demand-side management programs," *Power Systems, IEEE Transactions on*, vol. 9, no. 3, pp. 1691–1697, Aug 1994.
- [4] I. Berganza, A. Sendin, and J. Arriola, "Prime: Powerline intelligent metering evolution," June 2008, pp. 1–3.
- [5] A. Vojdani, "Smart integration," *Power and Energy Magazine, IEEE*, vol. 6, no. 6, pp. 71–79, November-December 2008.
- [6] *CS5464 datasheet. Three-channel, Single-phase Power/Energy IC*, 2007.
- [7] *PIC18F97J60 Family Data Sheet*, Microchip Technology Inc, 2007.
- [8] F. Cleveland, "Cyber security issues for advanced metering infrastructure (ami)," *Power and Energy Society General Meeting - Conversion and Delivery of Electrical Energy in the 21st Century, 2008 IEEE*, pp. 1–5, July 2008.