

Switched reluctance motor drive for 42 V electric power steering

P. Andrada, B. Blanqué, E. Martínez, J.I. Perat, J.A. Sánchez, M. Torrent

Grup d'Accionaments Elèctrics amb Commutació Electrònica (GAECE)
EPS d'Enginyeria de Vilanova i la Geltrú, Departament d'Enginyeria Elèctrica
Universitat Politècnica de Catalunya (UPC)
Av. Victor Balaguer s/n, 08800 Vilanova i la Geltrú, Spain
E-mail: andrada@ee.upc.edu

Abstract. In this paper, switched reluctance motors (SRM) are proposed as an alternative for electric power assisted steering (EPAS) applications. The new 42 V power voltage system is a very attractive design for a steering electric motor, both from a cost and size perspective. A four-phase 8/6 SRM drive is designed for a rack type EPAS which should provide a maximum force of 10 kN. Two-dimension finite element analysis is used to validate the design.

Keywords

Switched reluctance drive, design, electric power steering, automotive component.

1. Introduction

In modern cars, the use of electrical and electronic features to enhance comfort, convenience and safety has contributed to a sharp increase in power demands and in wiring harnesses. Consequently, the limitations of the 12 V power electric system have become apparent. The new 42 V Power-Net has emerged as a solution to these drawbacks and provides the opportunity to replace mechanically actuated systems with systems that are based on electronically controlled electric motors [1].

Electric power assisted steering (EPAS) is becoming an alternative to conventional hydraulic power steering. EPAS improves fuel economy, gives the capability to vary the assist according to the speed of the vehicle, provides assistance even when the internal combustion engine is switched off and enables an awkward fluid to be eliminated.

The main function of an EPAS is to provide steering assistance to the driver by means of an electronically controlled electric motor. The key components of an EPAS system are a combined torque and position sensor, an electric motor with a gear reduction mechanism, an electronic control unit, and control and diagnostic algorithms that are implemented in the software. There are different types of EPAS. The name of the system depends on the location of the electric motor and each

system is designed for a specific vehicle weight and size. The three main types are column assist for small cars, pinion assist for medium-sized cars, and rack assist for bigger cars [2-3]. The load requirements for these three types are shown in Table I.

TABLE I. Load requirements for the different types of EPAS

Types of EPAS	Car size	Load
Column assist	Small	6 kN
Pinion assist	Medium	8 kN
Rack assist	Large	12 kN

The electric motor should fulfill the following requirements:

- Production of smooth torque with minimum ripple
- High efficiency
- Fault-tolerant capability
- Minimum package size and weight

Different types of motors have been proposed for EPAS applications [4-8]. Table II shows a summary of the suitability of the motors developed for EPAS to date.

TABLE II. Comparison of Motors for EPAS

	DC motor	Brushless DC motor	Synchronous PM motor
Control	Armature	Square-wave	Sine wave/ Vector
Position Sensor	Not required	Hall sensors	Encoder/ Resolver
Power Converter	H-bridge	3-Phase Inverter	3-Phase Inverter
Inertia	High	Low	Low
Friction	High	Low	Low
Torque ripple	Low	High	Low

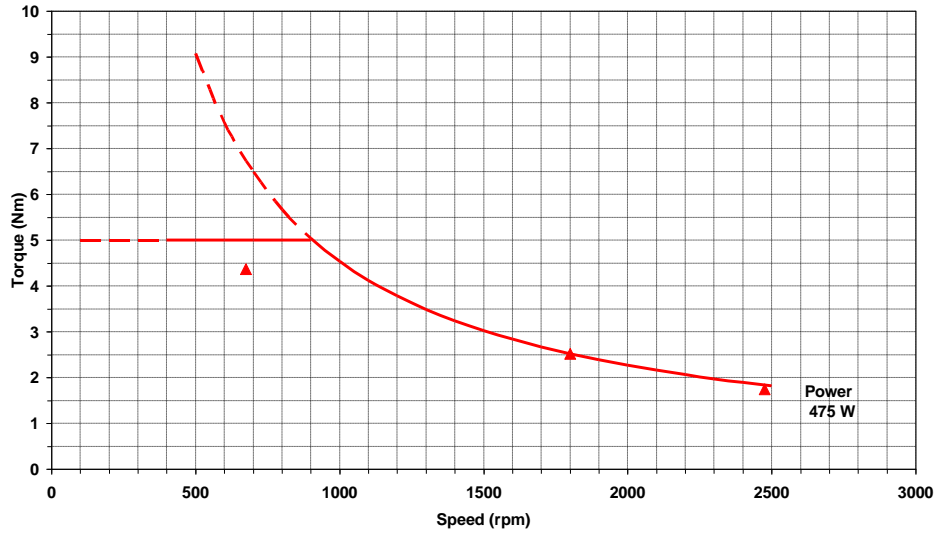

Fig. 1. Torque speed curve required for the SRM to provide a rack force of 10 kN

Although the brushless DC motor and permanent-magnet synchronous motors are the best-placed candidates, the switched reluctance motor (SRM) can be an attractive alternative due to its simple and rugged construction, its fault tolerant capability, and its high efficiency [9].

2. Design specifications

In this paper, an SRM drive is designed for rack-type EPAS systems that should provide a maximum rack force of 10 kN and the torque-speed characteristic given in Fig. 1. This requires electric motors with a mechanical output power of about 475 W and a torque of 2.52 Nm at 1800 rpm. The static peak force (10 kN) in stall conditions is forecast during the parking operation. It is required for a duty cycle of 5 s over 1 min. (S3 8.5%). The DC voltage is 42 V and the environmental temperature is between -40 °C and 125 °C.

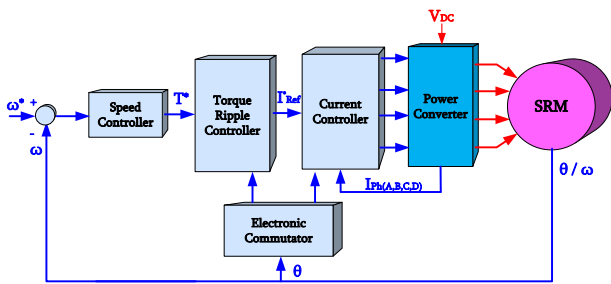

Fig. 2. Block diagram of the SRM drive

3. SRM drive design

A four-phase SRM with 8 stator poles and 6 rotor poles has been chosen to reduce torque dips and to ensure better behavior in fault conditions. The drawback of increasing the phase numbers is that more solid state switches are required in the power converter, which increases the cost and complexity of the drive. The control of the SRM drive must take into account the fact

that torque ripple minimization is a strong requirement [11]. The block diagram of the SRM drive is given in Fig. 2. The inner loop of the drive regulates the torque of the motor with the reference torque input, T^* , coming from an outer speed controller. The reference torque and the rotor position, through an electronic commutator, are used to fix the currents in the SRM phases by means of a current controller (either a hysteresis current controller or a PWM controller). Torque ripple can be minimized over a wider operating range by using electronic control techniques. The majority of these techniques use off-line or on-line computation of current profiles and a cascaded current controller. Most of these techniques are:

Indirect (controlled variable current or flux linkage)

- Current profiling with off-line calculation of profiles
- Current profiling with on-line calculation of profiles
- Flux linkage profiling with off-line calculation of profiles
- Harmonic injection

Direct (controlled variable instantaneous torque)

- Instantaneous torque control

The drive must also have specific controls to mitigate the effects of the faults.

In the 8/6 SRM, the external diameter, including the stator frame required for the application, is 94 mm and the air gap is fixed to 0.35 mm. In addition, several eco-design considerations were taken into account, namely:

- The number of materials should be reduced.
- The number of non-recyclable parts (i.e. plastics) should be minimized.
- The motor should be easily assembled and disassembled.
- The windings should be easy to remove.

The main SRM data can be found in Appendix I. Fig. 3 and Fig. 4 show photographs of the stator and the rotor of the 8/6 SRM.

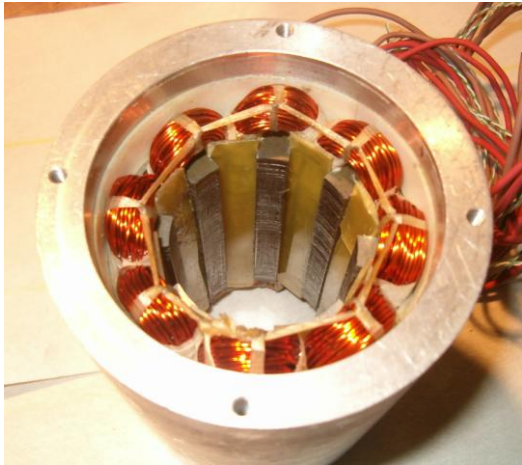

Fig. 3. Stator of the 8/6 SRM

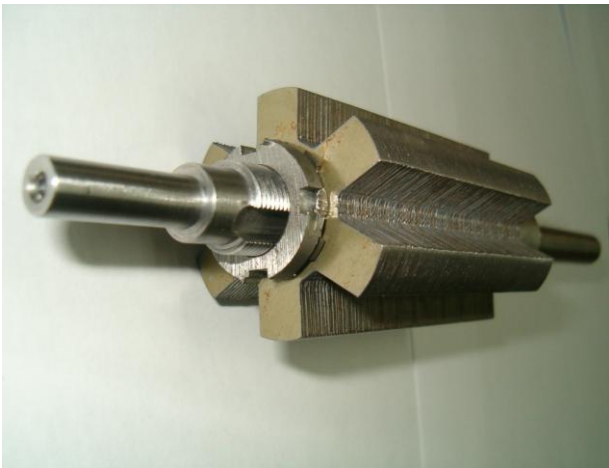

Fig. 4. Rotor of the 8/6 SRM

The power converter is an asymmetric bridge or classic converter with two switches and two diodes per phase (Fig. 5). The switches are n-channel Power Mosfets (Vishay Siliconix SUP90N06-05L) that are easily available; the diodes are power Schottky diodes (STMicroelectronics STPS16045TV). A resolver (TAMAGAWA TS2620N27 1 E 11) is chosen as a position and speed transducer.

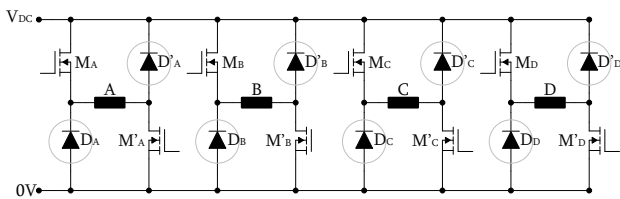

Fig. 5. Power converter, asymmetric bridge

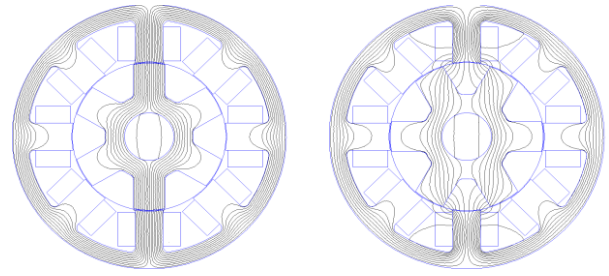

Fig. 6. Finite element flux plots in aligned (left) and unaligned (right) positions

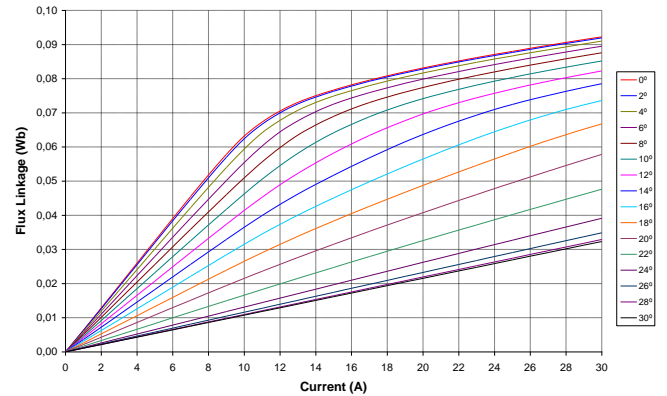

Fig. 7. Plots of flux linkage versus current for various rotor positions for the SRM

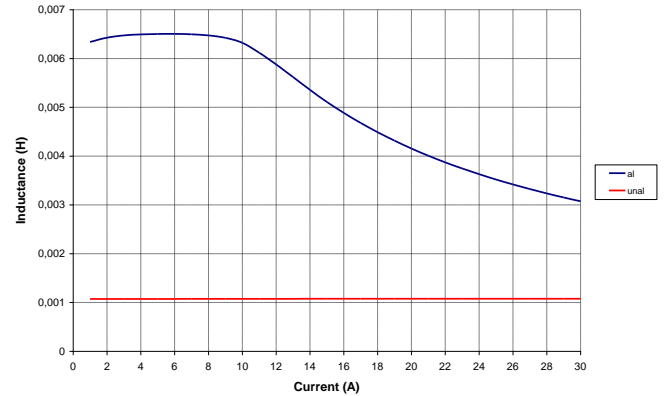

Fig. 8. Inductance versus current for the aligned and unaligned positions of the SRM

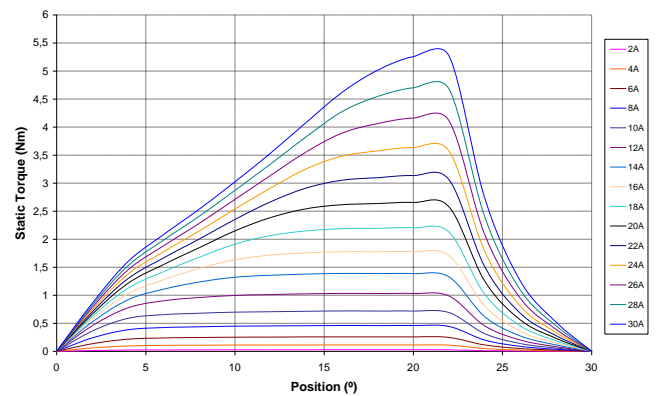

Fig. 9. Plots of torque versus rotor position for various current levels for the SRM

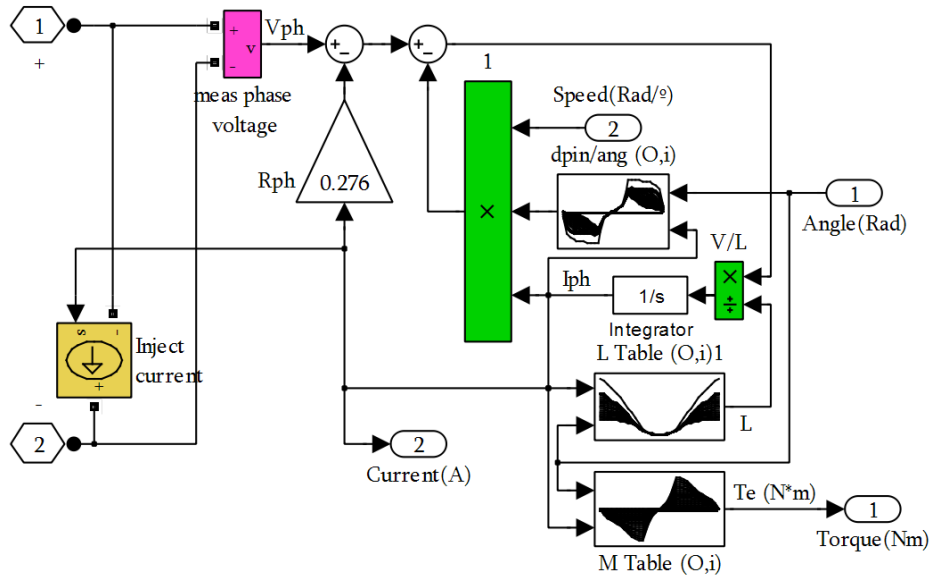

Fig. 10. Block diagram of the simulated 8/6 SRM

4. SRM drive simulation

a. 2D FEA simulation

As the length of the rotor is almost twice its diameter, two-dimension finite element analysis (2D FEA) is used to validate the design. No correction factor is required to take end effects into account [12]. Flux plots in the aligned and unaligned position (Fig. 6) are obtained using the FLUX 2D FEM package [13]. Flux-linkage versus current magnetization curves for different positions of the rotor are shown in Fig. 7. Inductance in the aligned and unaligned position for different current values is represented in Fig. 8. Static torque plots of torque versus position for various current levels, which were obtained by the method of virtual work, are shown in Fig. 8.

b. Simulink simulation

The simulation of the drive (including the SRM, power converter and control) was implemented in Matlab-Simulink using the 2D-FEA results. The 8/6 SRM block diagram is given in Fig. 10. Figs. 11, 12 and 13 show the voltage, phase current and torque waveforms for different load conditions.

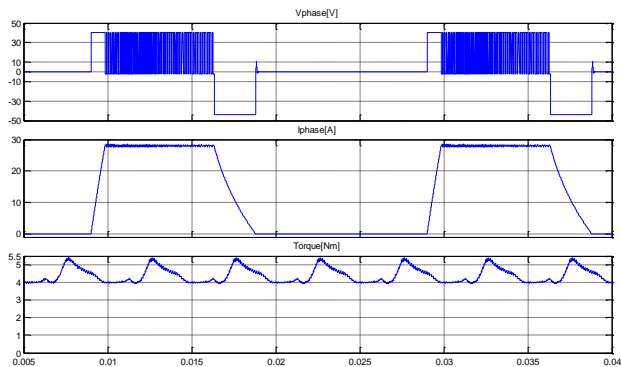

Fig.11. Voltage, current and torque waveforms at 500 rpm and a current reference of 28 A.

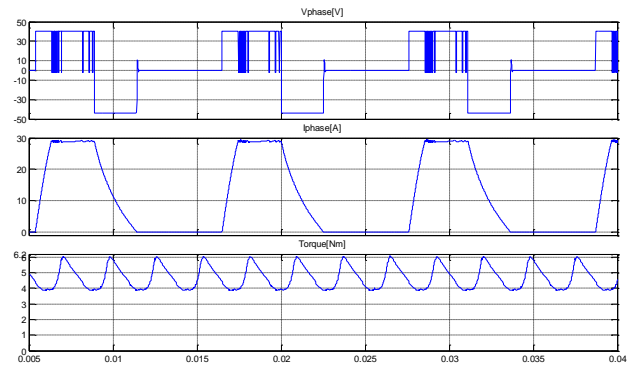

Fig. 12. Voltage, current and torque waveforms at 900 rpm and a current reference of 29 A

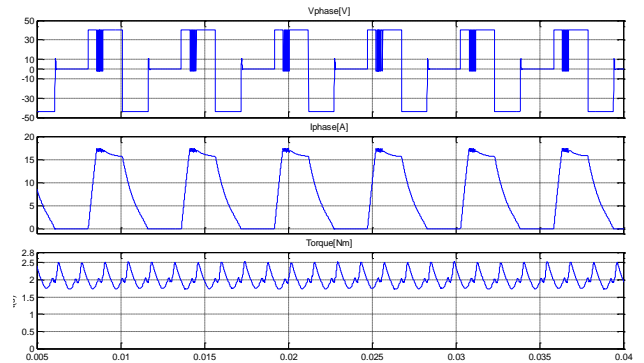

Fig. 13. Voltage, current and torque waveforms at 1800 rpm and current reference of 17 A

5. Conclusions

In this prospective paper, switched reluctance motor drives are proposed as an attractive alternative for EPAS applications. The new 42 V power voltage system is very attractive in the design of the steering electric motor, both from a cost and size perspective. A four-phase 8/6 SRM is designed for rack type EPAS, which should provide a maximum rack force of 10 kN. Finite element analysis and Simulink simulations validated the SRM.

Acknowledgments

This research was supported by the Spanish Ministry of Education and Science and the ERDF (DPI2006-09880).

References

- [1] Emadi, M. Ehsani, M. Miller, "Vehicular Electric Power Systems (Land, Sea, Air and Space Vehicles)." Marcel Dekker, 2004.
- [2] J.M. Miller, A. Emadi, A.V. Rajarathnam, M. Ehsani, "Current status and future trends in more electric car power systems." Proc. of 1999 IEEE Vehicular Technology Conference, Houston Texas, May 1999.
- [3] W. Ijiri and T. Tsutsui, "Technical Trends of Electric Power Steering Systems." Koyo Engineering Journal, English Edition No.162E (2003).
- [4] S. Murthy, T. Sebastian, B. Liu, "Implications of 42 V battery power on the design of motors for electric steering system." SAE Technical paper 2000-00FTT-58.
- [5] T. Tanaka, "Motors for electric power steering." Mitsubishi Electric ADVANCE. September 2003, pp.8-11.
- [6] G. Ombach, J. Junak, "Two rotors design's comparison of permanent magnet brushless synchronous motor for an electric power steering application." EPE 2007 Aalborg.
- [7] A.W. Barton, "Innovation drivers for electric power steering." IEEE Control Systems Magazine, December 2003, pp.30-39.
- [8] N. Bianchi, M. Dai Pré, S. Bolognani, "Design of fault tolerant IPM motor for electric steering". IEEE Transactions on Vehicular Technology, Vol 55, No 4, July 2006, pp.1102-1110.
- [9] D. Torrey, J. Kokernak, "Power steering Brushless DC or Switched Reluctance". Power Electronics Tech. 01.08.2002.
- [10] C. Oprea, C. Martis, "Fault tolerant permanent magnet synchronous machine for electric power steering systems". SPEEDAM 2008, pp. 256-261.
- [11] I. Hussain, "Minimization of torque ripple in SRM drives. IEEE Transactions on Industry Electronics", Vol 49, No 1 February 2002, pp 28-39.
- [12] A. Matveev, V. Kuzmichev, and E. Lomonova, "A new comprehensive approach to estimation of end-effects in switched reluctance motors", Proceedings ICEM 2002, Bruges Belgium, August 2002.
- [13] FLUX user's manual, www.cedrat.com

Appendix I SRM main data

Parameter	Symbol	Value
Stator outer diameter	D_0	78 mm
Stack length	L	81.6 mm
Stator inner diameter	D_i	69 mm
Stator air gap diameter	D_s	44 mm
Rotor air gap diameter	D	43.3 mm
Air gap	g	0.35 mm
Stator pole arc	β_s	20.95°
Rotor pole arc	β_r	24.16°
Stator pole width	b_s	8 mm
Rotor pole width	b_r	9 mm
Stator yoke thickness	h_y	4.5 mm
Rotor yoke thickness	h_n	5.5 mm
Stator slot depth	h_s	12.5 mm
Rotor slot depth	h_r	9 mm
Shaft diameter	D_e	14 mm
Shaft diameter (drive's end)	D_{out}	12 mm
Lamination steel		FeV 270-50 HA
Number of turns per pole	N_p	35
Wire diameter	d_c	1.15
Insulation class		H